

INDUSTRIAL PARTITION WALLS

**DEFLECTION HEAD TRACK DETAIL
BLOCKING & BRACING**

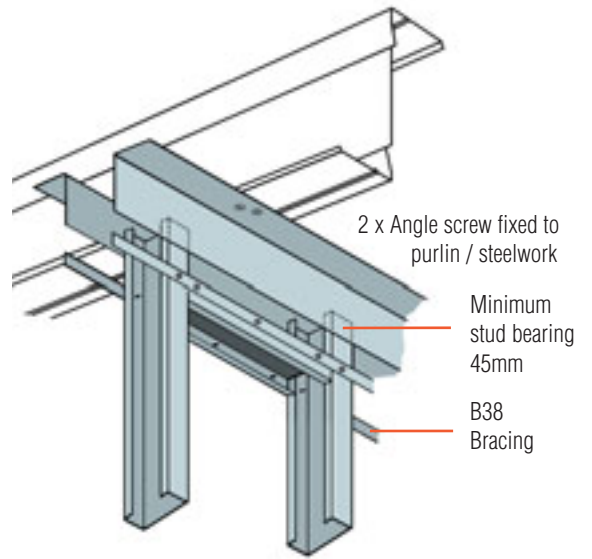

**LATERAL RESTRAINT
BLOCKING & BRACING**

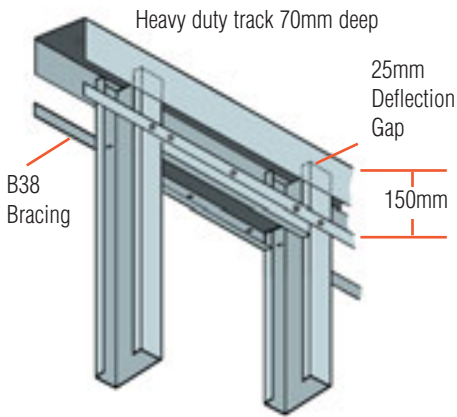
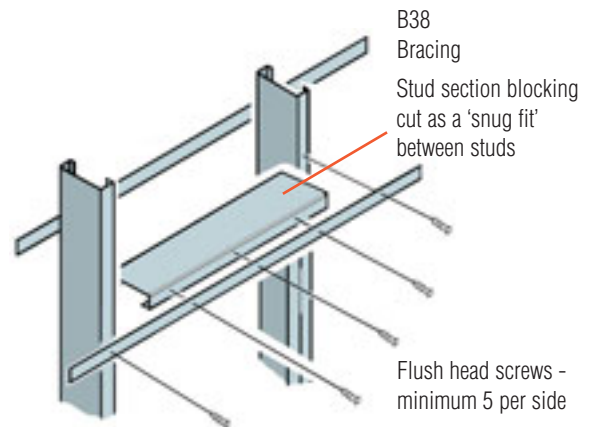
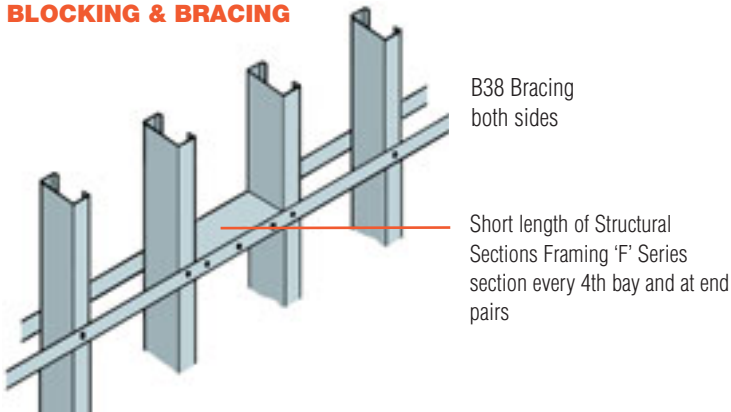

OPENING LINTEL CONSTRUCTION

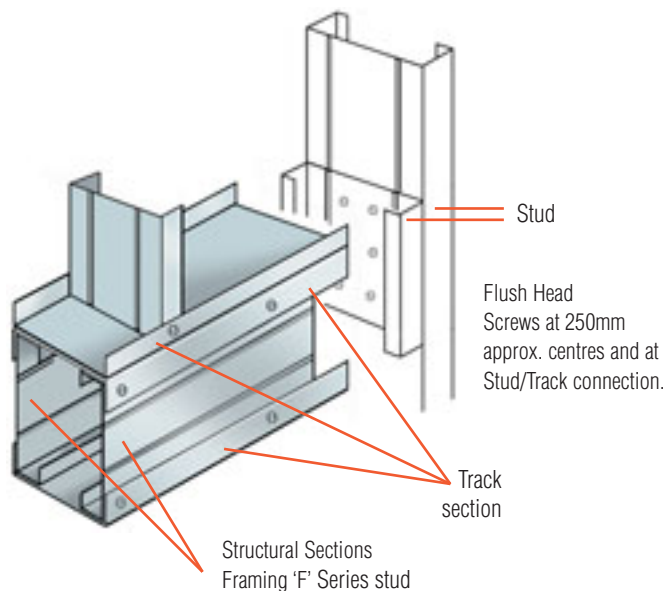

FLOOR TRACK

